

**TerraGator**



# TERRAGATOR

TG7300C / TG8300C TERRAGATOR CHASSIS (2019)

## Parts and Service Guide

**ZIEGLER**  
AG EQUIPMENT

# TERRAGATOR Specifications\*

ENGINE	TG7300C	TG8300C
Make	AGCO Power	AGCO Power
Type	AP84-4	AP84-4
Number of Cylinders	6	6
Displacement	8.4 L (513 CID)	8.4 L (513 CID)
Horsepower	332 HP (247 kW) @ 2,100 rpm	365 HP (272 kW) @ 2,100 rpm
Peak Horsepower	363 HP (270 kW) @ 1,900 rpm	393 HP (293 kW) @ 1,900 rpm
Torque	1,180 ft-lbs (1,600 N-m) @ 1,500 rpm	1,180 ft-lbs (1,600 N-m) @ 1,500 rpm

## TRANSMISSION

Type	AGCO ML-260 Continuously Variable Transmission	AGCO ML-260 Continuously Variable Transmission
Forward Speed (high/low)	41 mph / 23 mph (67 kmh / 37 kmh)	41 mph / 23 mph (67 kmh / 37 kmh)

## DRY SYSTEM

AirMax Precision**	Single bin, 355 cu.ft. (10.1 m <sup>3</sup> )	Single bin, 355 cu.ft. (10.1 m <sup>3</sup> )
AirMax Precision 2**		Adjustable, split bin, 345 cu.ft. (9.8 m <sup>3</sup> )
Soilection Twin Bin***		Two bins, 320 cu.ft. (9.1 m <sup>3</sup> )
New Leader NL4500	Single bin, MultiApplier insert, MultiBin, up to 331 cu.ft. (9.3 m <sup>3</sup> )	Single bin, MultiApplier insert, MultiBin, up to 331 cu.ft. (9.3 m <sup>3</sup> )
New Leader NL5000	Single bin, MultiApplier insert, MultiBin, up to 331 cu.ft. (9.3 m <sup>3</sup> )	Single bin, MultiApplier insert, MultiBin, up to 331 cu.ft. (9.3 m <sup>3</sup> )

## LIQUID SYSTEM

### TG7300C/TG8300C

Capacity	1,800 gal. (6,814 L)
Pump	260 GPM (984 LPM)
Booms	60/80 ft. (18/24 m) fold-over boom 80 ft. (24 m)
Breakaway, Full Boom	Hydraulic, resettable
Breakaway, Boom Tip	Mechanical, spring return
Height / Tilt Adjustment	Hydraulic
Nozzle Spacing	30 in. (0.76 m) or 60 in. (1.52 m)
Total Spray Width	82.5 ft. (25.1 m) on 30 in. centers; 85 ft. (25.9 m) on 60 in. centers

## AIR SYSTEM

Compressor	Engine-mounted
Governor	120 psi (8.2 bar)
CFM	14.1 cfm (6.7 L/s)
Reservoir	Dual

## AXLES

Front	3.75-in.-diameter (9.5 cm) freewheeling, cold-rolled solid steel
Rear	Wide track 42,000-lb. rating with flotation tires

## TIRES

Standard	Goodyear® Radial 1000/50R25
Optional	Michelin® Radial 1000/50R25

## SUSPENSION

Type	Rigid rear axle to frame mount
------	--------------------------------

# TERRAGATOR Specifications\* (cont.)

## STEERING **TG7300C/TG8300C**

---

Type Dynamic load sense

## WEIGHTS

---

Rated Capacity Front 14,000 lbs. (6,350 kg)  
Rated Capacity Rear 42,000 lbs. (19,050 kg)

## APPLICATION CAB

---

Glass Area / Floor Area 58 sq.ft. (5.4 m<sup>2</sup>) / 14 sq.ft. (1.39 m<sup>2</sup>)  
Cab Suspension Air-ride cab  
Radio AM/FM / stereo, USB MP3-compatible, Weather band, Bluetooth® with mic., Opt. SiriusXM®  
HVAC / Filtration Automatic temperature control / 3-level activated carbon  
Standard Seat Cloth with air-ride suspension  
Optional Seat Leather heated-vented with air-ride suspension

## FLUID CAPACITIES

---

Fuel 165 gal. (625 L)  
DEF (Diesel Exhaust Fluid) 15 gal. (56.8 L)  
Engine Coolant 8 gal. (30.3 L)  
Engine Oil 6 gal. (22.7 L)  
Transmission Oil 14 gal. (53 L)  
Hydraulic Reservoir 12 gal. (46 L)

## CONTROLLERS

---

Controllers Available Raven Viper 4+

\* Specifications are manufacturer's estimates at time of publication and are subject to change without prior notification. Actual weight will vary depending on optional equipment.

\*\* Single 40 cu.ft. (1.13 m<sup>3</sup>) granular bin available

\*\*\* Dual 25 cu.ft. (0.7 m<sup>3</sup>) granular bins available

# TERRAGATOR Parts List

ITEM	PART NUMBER	QTY	DESCRIPTION	TECHNICAL SPECIFICATION
1	568310D1	1	Air Filter Element – Primary Air Filter	
2	568311D1	1	Air Filter Element – Safety	
3	72311028	1	Filter Element – Transmission High Pressure	
	72312070	1	Oil Filter Element – Transmission Suction	
4	AG520617	1	Suction Strainer – Hydraulic	2.5"
5	532430D1	1	Filter Element – Hydraulic	
6	556653D1	1	Cab Filter	
7	556654D1K	1	Cab Filter – Carbon	
8	AG718281	1	Air Filter Element – Cab	Particle
9	V836379588	1	Engine Oil Filter	
10	AG524540	1	Inline Strainer	100 Mesh
11	V837091129	1	Fuel Filter Kit	
	3905873M91	1	Fuel Filter Element – Water Separator	
12	567109D1	1	Belt – A/C Belt	1218 mm
	V685122255	1	Multi-Ribbed Belt – Fan Belt	
13	V837079423	1	DEF Filter	
14	AG330202	1	Filter – Air Dryer	

## TO ORDER:

Call or visit your nearest Ziegler location. Visit [www.zieglercat.com/contact](http://www.zieglercat.com/contact) for a directory.

# TERRAGATOR Machine Diagram

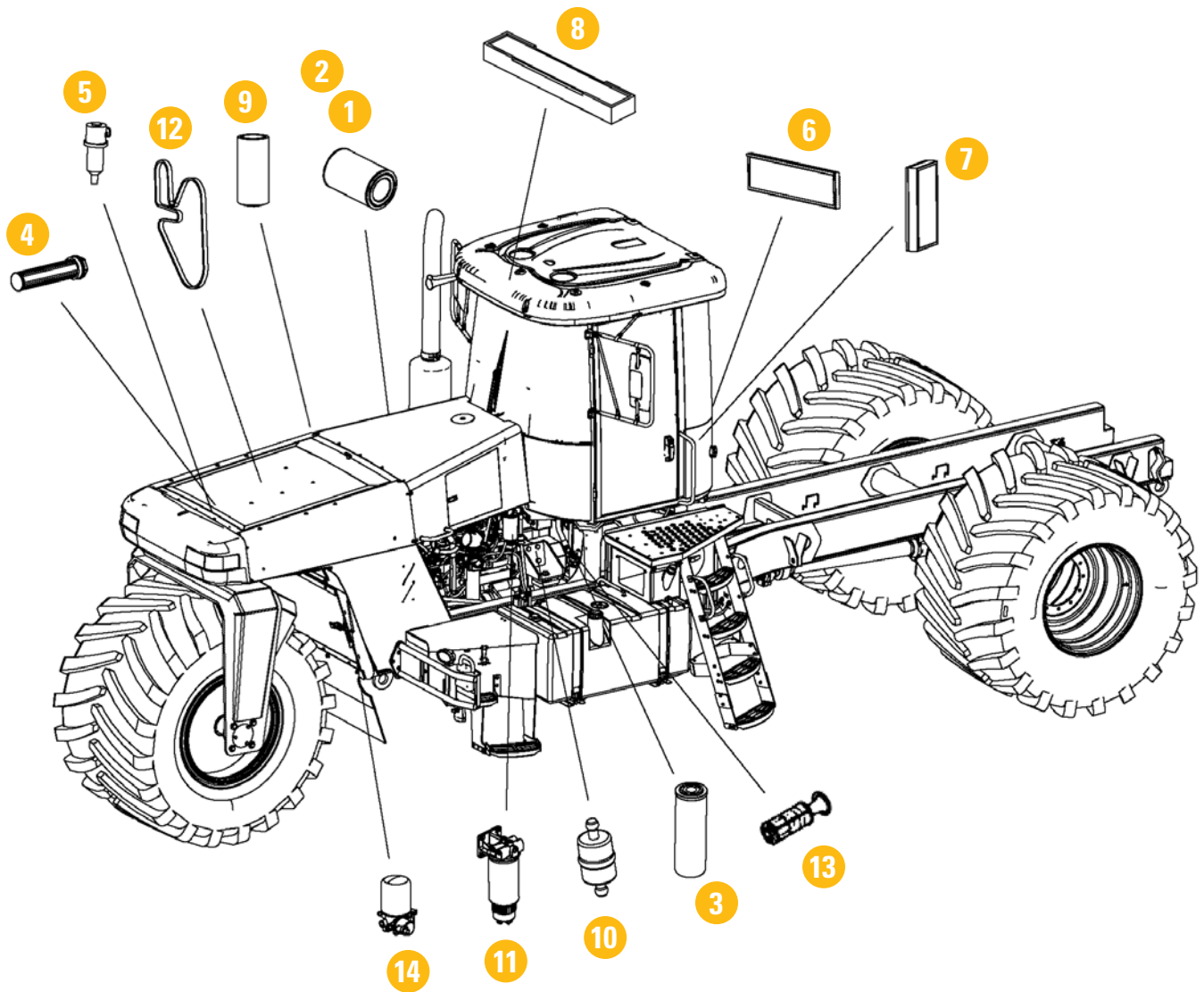

# TERRAGATOR Service Guide

SERVICE ITEMS	INTERVAL										PARTS AND LUBRICANTS		
	Initial 100	100	250	400	500	800	1000	2000	Annual	Comprehensive	Part # / Charge Code	Qty	Description
Clean the cooling system (from outside)	X	X		X	X	X	X	X		X			
Check the condition of the belt	X	X		X	X	X	X	X		X			
Change the engine oil and filter				X		X		X	X	X	V837074523	1	Engine Oil Filter
											SAMPLE	6	AGCO 15W-40 CI-4 ENGINE OIL GAL
											SAMPLE	1	Sample
Change the fuel filters						X			X	X	V837091129	1	Fuel Filter Kit
											3905873M91	1	Fuel Water Separator
Check/administer engine software update				X		X		X		X			
Check the torque on rear and front wheel nuts	X	X		X	X	X	X	X		X			
Check the torque on the charge air hose clamps and hose from the turbo to the CAC	X							X	X	X			
Replace the inline fuel strainer	X							X	X	X	AG524540	1	Inline Strainer
Lubricate the tag axle fittings (if equipped)	Service Item not included in PM – create separate segment for service												
Lubricate front wheel bearings	X	X	X	X	X	X	X	X		X	79017915	1	MOLY EP Grease
Check the rear axle mounting bolts, tighten to torque of 424 lbf ft	X							X	X	X			
Check brake air lines	X	X	X	X	X	X	X	X		X			
Replace the hydraulic oil filter	X							X	X	X	587603D1	1	Hydraulic Filter
Replace the hydraulic oil								X	X	X	SAMPLE"	14	AGCO 821XL 10W-30 PERMATRAN GAL
											SAMPLE"	1	Sample
Replace the CVT high pressure filter	X							X	X	X	72311028	1	High Pressure Filter
											72313495"	1	O-Ring
Replace the pressure washer pump oil	X				X		X	X	X	X			See lubricant table below
Check front and rear cab mounts	X	X		X	X	X	X	X		X			
Lubricate the steering cylinder ends	X	X		X	X	X	X	X		X	79017915	1	MOLY EP Grease
Drain the water and sediment out of the fuel tank	X	X		X	X	X	X	X		X			
Check the differential and planetary oil level		X		X	X	X		X					
Drain the water and sediment out of the fuel tank	X	X		X	X	X	X	X		X			
Check the differential and planetary oil level		X		X	X	X		X					
Replace the differential and planetary oil	X							X	X	X	79014722	3	AGCO Gear Lubricant/ Axle Oil 2.5 GAL
											AG331201	1	O Ring
											AG331200	1	O Ring
											SAMPLE	3	Samples
Clean the differential breather	X	X		X	X	X	X	X		X			
Check the tag axle bearing bolt torque (if equipped)	Service Item not included in PM – create separate segment for service												
Check brakes manual slack adjusters (if equipped)	Service Item not included in PM – create separate segment for service												
Inspect and clean the cab air filters			X		X		X	X					
Lubricate grease fittings on driveline			X		X		X	X		X	79014728	1	Multi-Purpose Lithium II Grease
Check the clutch master cylinder fluid; check for correct operation				X		X		X		X			
Replace the air dryer filter					X		X	X		X	AG330202	1	Air Dryer Filter
Lubricate the brake slack adjuster on the rear axle					X		X	X		X	79017915	1	MOLY EP Grease
Check the engine-to-frame ground connections					X		X	X		X			
Check driveline U-joints					X		X	X		X			
Replace the receiver-dryer (A/C system)							X	X	X	X	593052D2	1	A/C Receiver Drier
Replace the primary engine air filter							X	X	X	X	568310D1	1	Primary Engine Air Filter
Replace the pressure washer strainer							X	X	X	X	AG513640	1	Inline Pressure Washer Strainer
											556653D1	1	Cab Filter
Replace the cab air filters									X	X	556654D1K	1	Cab Carbon Filter
											AG718281	1	Particle Filter

## LUBRICANTS

Component	Oil type/Class	Viscosity	US GAL	# of Components	Part # / Charge Code	Description
Rear axle differential and planetary	GL-5	80W-90	6.5	1	79014722	AGCO Gear Lubricant/ Axle Oil 2.5 GAL
Hydraulic system	Permatran 821XL	10W-30	13.5	1		AGCO 821XL 10W-30 PERMATRAN GAL
Transmission	Permatran 821XL PLUS	15W-40	15.1	1		AGCO 821XL PLUS 15W-40 TRAN OIL GAL
Engine oil	CJ-4	15W-40	6	1		AGCO 15W-40 CI-4 ENGINE OIL GAL
Grease fittings	high temp moly-lithium base grease			1	79017915	MOLY EP Grease
Pressure wash pump	NON-Detergent oil	30W	0.0935	1		
Grease fittings on driveline	high temp NLGI #2 multi-purpose moly-free lithium grease			1	79014728	Multi-Purpose Lithium II Grease
CVT clutch oil	Pentosin CHF 11S					
Engine coolant	50/50 water & ethylene glycol without stop leak additive with SCA	50/50	8.2	1	ZXRU1	PREMIX COOLANT