

Cat® D250 GC DIESEL GENERATOR SETS



Standby: 60 Hz, 208V, 480V & 600V



Image shown might not reflect actual configuration

Engine Model	Cat® C9 In-line 6, 4-cycle diesel
Bore x Stroke	112mm x 149mm (4.4in x 5.9in)
Displacement	8.8 L (538 in ³)
Compression Ratio	16.3:1
Aspiration	Turbocharged Air-to-Air Aftercooled
Fuel Injection System	HEUI
Governor	Electronic ADEM™ A4

Standby	Performance Strategy
250 ekW, 312.5kVA	EPA Certified for Stationary Emergency Application

PACKAGE PERFORMANCE

Performance	Standby	
Frequency	60 Hz	
Genset Power Rating	312.5 kVA	
Gen set power rating with fan @ 0.8 power factor	250 ekW	
Emissions	EPA TIER 3	
Performance Number	DM8501	
Fuel Consumption		
100% load with fan	73.3 L/hr	19.4 gal/hr
75% load with fan	58.8 L/hr	15.5 gal/hr
50% load with fan	43.8 L/hr	11.6 gal/hr
25% load with fan	27.4 L/hr	7.3 gal/hr
Cooling System ¹		
Radiator air flow restriction (system)	0.12 kPa	0.48 in. Water
Radiator air flow	497 m ³ /min	17551 cfm
Engine coolant capacity	14 L	3.69 gal
Radiator coolant capacity	25 L	6.6 gal
Total coolant capacity	45 L	11.88 gal
Inlet Air		
Combustion air inlet flow rate	23.83 m ³ /min	841.5 cfm
Max. Allowable Combustion Air Inlet Temp	49 °C	120 °F
Exhaust System		
Exhaust stack gas temperature	460 °C	860 °F
Exhaust gas flow rate	63.6 m ³ /min	2246 cfm
Exhaust system backpressure (maximum allowable)	10.0 kPa	40.0 in. water
Heat Rejection		
Heat rejection to jacket water	104 kW	5928 Btu/min
Heat rejection to exhaust (total)	277 kW	15772 Btu/min
Heat rejection to aftercooler	82 kW	4686 Btu/min
Heat rejection to atmosphere from engine	18 kW	1004 Btu/min
Heat rejection from alternator	20 kW	1120 Btu/min

Emissions (Nominal) ²	Standby		
NOx	1637.5 mg/Nm ³	3.14 g/hp-hr	
CO	323.2 mg/Nm ³	0.68 g/hp-hr	
HC	71.2 mg/Nm ³	0.17 g/hp-hr	
PM	63.7 mg/Nm ³	0.16 g/hp-hr	
Alternator ³			
Voltages	480V	208	600V
Motor Starting Capability @ 30% Voltage Dip	567	544	1006
Current	375.9	867.4	300.7
Frame Size	M2754L4	M2774L4	M2754L4
Excitation	S.E	S.E	AREP
Temperature Rise	105°C	105°C	105°C

WEIGHTS & DIMENSIONS – OPEN SET

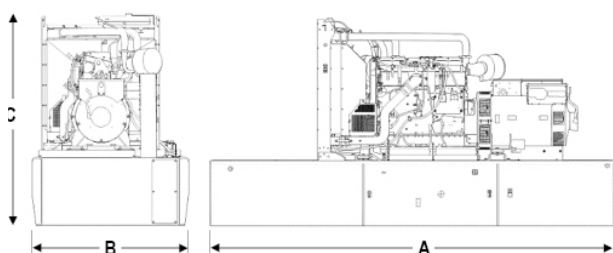

Base	Dim "A" mm (in)	Dim "B" mm (in)	Dim "C" mm (in)	Generator Set Weight kg (lb)
Skid (Wide Base)	3950 (155.5)	1440 (56.7)	1706 (67.2)	2415 (5324.2)
Integral Tank Base	3950 (155.5)	1430 (56.3)	2202 (86.7)	3055 (6735.1)

FUEL TANK CAPACITY

Tank Design	Total Capacity		Useable Capacity	
	Litre	Gallon	Litre	Gallon
Integral	2270	600	2059	544

DEFINITIONS AND CONDITIONS

¹ For ambient and altitude capabilities consult your Cat dealer. Air flow restriction (system) is added to existing restriction from factory.

² Emissions data measurement procedures are consistent with those described in EPA CFR 40 Part 89, Subpart D & E and ISO8178-1 for measuring HC, CO, PM, NOx. Data shown is based on steady state operating conditions of 77° F, 28.42 in HG and number 2 diesel fuel with 35° API and LHV of 18,390 BTU/lb. The nominal emissions data shown is subject to instrumentation, measurement, facility and engine to engine variations. Emissions data is based on 100% load and thus cannot be used to compare to EPA regulations which use values based on a weighted cycle.

³ UL 2200 Listed packages may have oversized generators with a different temperature rise and motor starting characteristics. Generator temperature rise is based on a 40° C ambient per NEMA MG1-32.

APPLICABLE CODES AND STANDARDS:

AS1359, CSA C22.2 No100-04, UL142, UL489, UL869, UL2200, NFPA37, NFPA70, NFPA99, NFPA110, IBC, IEC60034-1, ISO3046, ISO8528, NEMA MG1-22, NEMA MG1-33, 2006/95/EC, 2006/42/EC, 2004/108/EC.

Note: Codes may not be available in all model configurations. Please consult your local Cat Dealer representative for availability.

STANDBY: Output available with varying load for the duration of the interruption of the normal source power. Average power output is 70% of the standby power rating. Typical operation is 200 hours per year, with maximum expected usage of 500 hours per year.

RATINGS: Ratings are based on SAE J1349 standard conditions. These ratings also apply at ISO3046 standard conditions.

Fuel Rates are based on fuel oil of 35° API [16° C (60° F)] gravity having an LHV of 42 780 kJ/kg (18,390 Btu/lb) when used at 29° C (85° F) and weighing 838.9 g/litre (7.001 lbs/U.S. gal.). Additional ratings may be available for specific customer requirements, contact your Caterpillar representative for details. For information regarding Low Sulfur fuel and Biodiesel capability, please consult your Cat dealer.

LEHE2023-02 (05-20)

www.Cat.com/electricpower

© 2020 Caterpillar All rights reserved. Materials and specifications are subject to change without notice. The International System of Units (SI) is used in this publication. CAT, CATERPILLAR, their respective logos, "Caterpillar Corporate Yellow", the "PowerEdge" and Cat "Modem Hex" trade dress as well as corporate and product identity used here in, are trademarks of Caterpillar and may not be used without permission.

SOUND ATTENUATED LEVEL 2

ENCLOSURES

D250GC – D600GC

60 Hz



Image shown might not reflect actual configuration

FEATURES

Robust / Highly Corrosion Resistant Construction

- Factory installed on skid base or tanks base
- Environmentally friendly, polyester powder baked paint
- Enclosure constructed with 18-gauge steel
- Interior zinc plated fasteners
- Internally mounted exhaust silencing system
- Comply with ASCE/SEI 7 for Wind loads up to 100mph
- Designed and tested to comply with UL 2200 Listed generator set package

Excellent Access

- Large cable entry area for installation ease.
- Accommodates side mounted single or multiple breakers.
- Two doors on both sides.
- Vertically hinged allow 180° opening rotation
- Radiator fill cover.

Security and Safety

- Lockable access doors which give full access to control panel and breaker.
- Cooling fan and battery charging alternator fully guarded.
- Fuel fill, oil fill and battery can only be reached via lockable access.
- Externally mounted emergency stop button (Optional).
- Designed for spreader bar lifting to ensure safety.
- Stub-up area is rodent proof.

Sound Attenuated Level 2

- Caterpillar white paint
- UL Listed integral fuel tank with 24 hours running time capacity (Optional).
- DC lighting package (Optional)

Enclosure Package Operating Characteristics

Enclosure Type	Standby ekW	Cooling Air Flow Rate		Ambient Capability*		Sound Pressure Levels (dBA) at 7m (23 ft)
		m ³ /s	cfm	°C	°F	100% Load
Level 2 Sound Attenuated Enclosure (Steel)	250	6.4	13561	57	135	74
	300	6.4	13561	51	125	74
	350	7.4	15680	57	134	71
	400	7.4	15680	53	127	71
	450	8.4	17692	54	130	73
	500	8.4	17692	50	122	73
	550	11.2	23731	56	133	73
	600	11.2	23731	53	127	73

*Cooling system performance at sea level. Consult your Cat[®] dealer for site specific ambient and altitude capabilities.

Note: Sound level measurements are subject to instrumentation, installation and manufacturing variability, as well as ambient site conditions.

DIMENSIONS

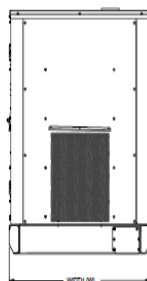
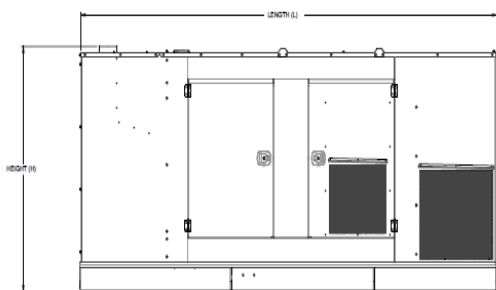

Sound Attenuated Enclosure on Skid Base

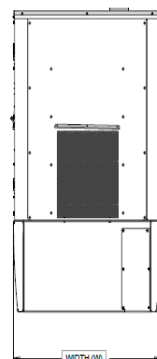
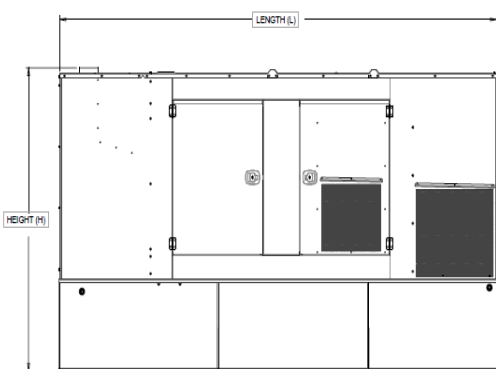

Sound Attenuated Enclosure on a UL Listed Integral Fuel Tank Base

Image shown might not reflect actual configuration

WEIGHTS & DIMENSIONS

Enclosure Type	Standby Ratings, ekW	Length, L		Width, W		Height, H		Package Weights	
		mm	in	mm	in	mm	in	kg	lb
Sound Attenuated Enclosure on Skid Base	250	3958	155.8	1440	56.7	1991	78.4	2857	6298.6
	300							2945	6492.6
	350	4633	182.4	1630	64.2	2227	87.7	3983	8781.0
	400							4017	8856.0
	450	4823	189.8	1630	64.2	2777	109.3	4408	9718.0
	500							4457	9826.0
	550	4980	196.1	1865	73.4	2723	107.2	4754	10480.8
	600							4837	10663.8
Sound Attenuated Enclosure on UL Listed Integral Fuel Tank Base	250	3958	155.8	1440	56.7	2487	97.9	3497	7709.6
	300							3585	7903.6
	350	4633	182.4	1630	64.2	2644	104.1	4765	10505.0
	400							4799	10580.0
	450	4823	189.8	1630	64.2	2777	109.3	5345	11783.7
	500							5394	11891.7
	550	4980	196.1	1865	73.4	2723	107.2	5973	13168.2
	600							6056	13351.2

LET'S DO THE WORK.™

LEHE2014-02 (09-19)

www.Cat.com/electricpower

©2019 Caterpillar All rights reserved. Materials and specifications are subject to change without notice. The International System of Units (SI) is used in this publication. CAT, CATERPILLAR, their respective logos, "Caterpillar Yellow", the "Power Edge" and Cat "Modern Hex" trade dress as well as corporate and product identity used herein, are trademarks of Caterpillar and may not be used without permission.

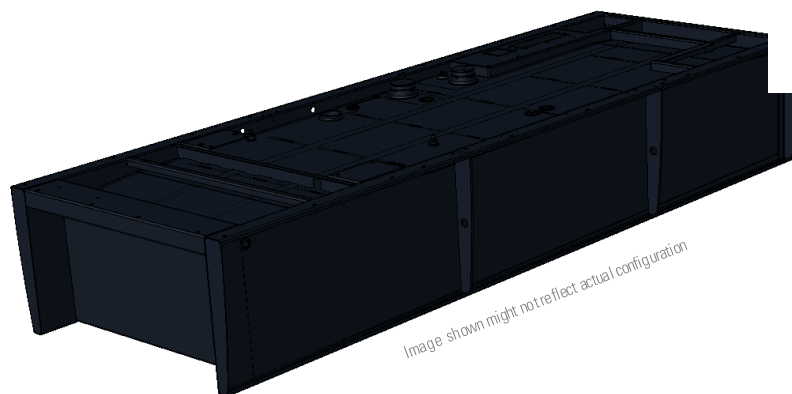

INTEGRAL FUEL TANKS D250 GC – D600 GC

FEATURES

- UL Listed for United States (UL 142) and Canada (CAN/ULC S601)
- Facilitates compliance with NFPA 30 code, NFPA 37 and 110 standards and CSA C282 code
- Dual wall
- Low fuel level warning standard, customer configurable warning or shutdown
- Primary tank leak detection switch in containment basin
- Tank design provides capacity for thermal expansion of fuel
- Fuel supply dip tube is positioned so as not to pick up fuel sediment
- Fuel return and supply dip tube is separated by an internal baffle to prevent immediate re-supply of heated return fuel
- Pressure washed with an iron phosphate solution
- Interior tank surfaces coated with a solvent-based thin-film rust preventative
- Heavy gauge steel gussets with internal lifting rings
- Primary and secondary tanks are leak tested at 20.7 kPa (3 psi) minimum
- Compatible with open packages and enclosures
- Gloss black polyester alkyd enamel exterior paint
- Welded steel containment basin (minimum of 110% of primary tank capacity)
- Direct reading fuel gauge with variable electrical output
- Emergency vents on primary and secondary tanks are sized in accordance with NFPA 30.

INTEGRAL

- Integral diesel fuel tank is incorporated into the generator set base frame
- Robust base design includes linear vibration isolators between tank base and engine generator.

OPTIONS

- Audio/visual fuel level alarm panel
- 5gal (18.9 L) spill containment*
- Locking Fuel Fill
- Overfill prevention Valve*

*Applicable for D350GC-D600GC Models only

Integral Fuel Tank Base Useable Capacities with Fuel Tank Dimensions & Weights

Standby ekW	Width mm	Width in
250-300	1430	56.3
350-400	1630	64.1
450-500	1630	64.1
550-600	1865	73.4

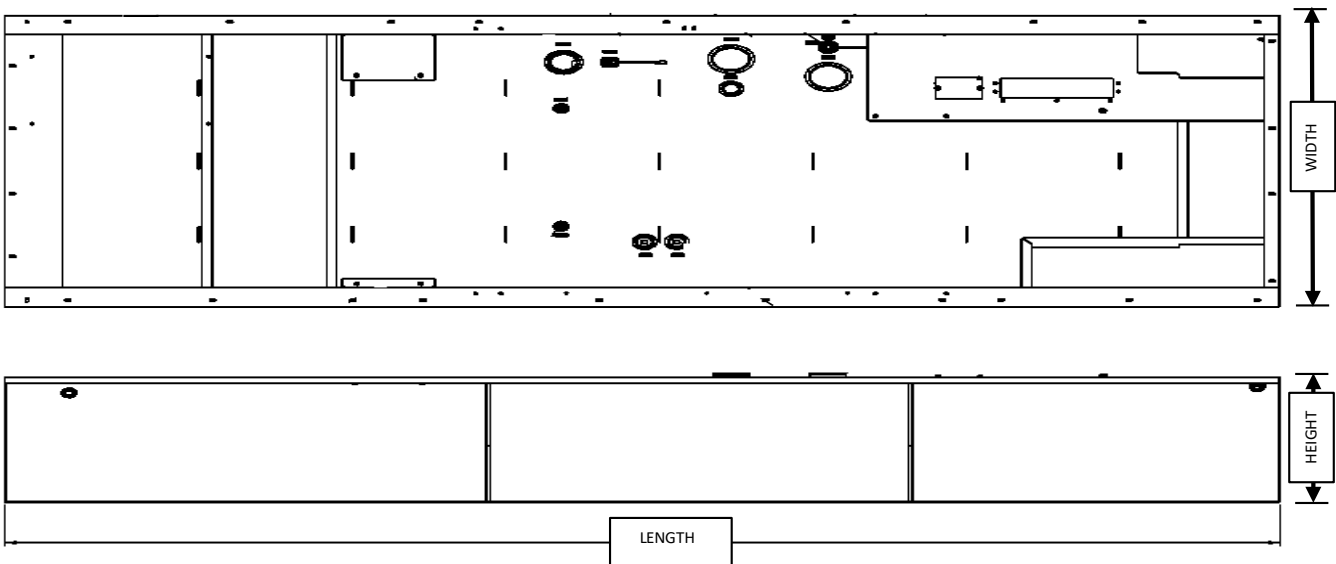

The heights listed above do not include lumber used during manufacturing and shipping

A. Open Set & Sound Attenuated Enclosure

Tank Design	Feature Code	Total Capacity		Useable Capacity		Tank Only						Overall Package Height with Tank			
						Dry Weight		Height 'H'		Length 'L'		Open		Enclosure	
		Litre	Gallon	Litre	Gallon	kg	lb	mm	in	mm	in	mm	in	mm	in
Integral Tank	FTDW035	2270.7	599.8	2059.9	543.9	970	2138	762.4	30.0	3958	155.8	2202	86.7	2487	97.9
	FTDW036	2820	744.9	2553	674.4	1165	2568	818.8	32.2	4815	189.5	2584	101.7	2644	104
	FTDW037	3671	969.7	3323	877.8	1331	2934	668.2	26.3	4622	181.9	2456	96.7	2644	104
	FTDW038	4292	1133.8	3889	1027.3	1657	3653	816.4	32.1	4980	196	2560	100.7	2721	107.1

B. Estimated Run Time (Hours)

Tank Design	Feature Code	Standby Ratings (kVA)						
		ekW	100%		75%		50%	
			Hrs	L/hr	Hrs	L/hr	Hrs	L/hr
Integral Tank	FTDW035	250	28.1	73.3	35	58.8	47	43.8
		300	24	86.0	30.8	66.8	40	51.5
	FTDW036	350	27.1	94.3	31.2	81.9	42.4	60.2
		400	24.1	105.9	28.1	90.7	38.6	66.2
	FTDW037	450	25.2	131.7	31.3	106.1	42.0	79.1
		500	24.3	137	30.1	110.5	46.6	71.3
	FTDW038	550	25.7	151.1	32.9	118.1	45.2	86.1
		600	24.1	161.6	30.0	129.6	42.4	91.7

Tanks with full electrical stub-up area include removable end channel. Tanks with RH stub-up include stubup area directly below the circuit breaker or power terminal strips.

Fuel tanks and applicable options facilitate compliance with the following United States NFPA Code and Standards:

NFPA 30: Flammable and Combustible Liquids Code

NFPA 37: Standard for the Installation and Use of Stationary Combustion Engines and Gas Turbines

NFPA 110: Standard for Emergency and Standby Power Systems

Fuel tanks and applicable options facilitate compliance with the following Canadian Standard and Code:

CSA C282 – Emergency Electrical Power Supply for Buildings

CSA B139-09 – Installation Code for Oil-Burning Equipment



Image shown might not reflect actual configuration

GCCP 1.2 - Control Panel

GCCP 1.2 is an auto Start Control Module suitable for a wide variety of diesel generator applications. Monitoring an extensive number of engine parameters, the modules will display warnings, shutdown and engine status information on the backlit LCD screen, illuminated LEDs and remote PC.

FEATURES

- 4-line back-lit LCD text display
- Multiple display languages
- Five-key menu navigation
- LCD alarm indication
- Customisable power-up text and images
- Data logging facility
- Internal PLC editor
- Protections disable feature
- Fully configurable via PC using USB & RS485 communication
- Front panel configuration with PIN protection
- Power save mode
- 3-phase generator sensing and protection
- Generator current and power monitoring (kW, kvar, kVA, pf)
- kW and kvar overload and reverse power alarms
- Over current protection
- Unbalanced load protection
- Breaker control via fascia buttons
- Fuel and start outputs configurable when using CAN
- Support for 0V to 10 V & 4 mA to 20 mA sensors
- 8 configurable digital inputs (3 available for Customer use)
- 8 configurable digital outputs (5 available for Customer use)
- 4 configurable analogue outputs (3 available for Customer Use)
- CAN, MPU and alternator frequency speed sensing in one variant
- Real time clock
- Engine pre-heat and post-heat functions
- Engine run-time scheduler
- Engine idle control for starting & stopping
- Fuel usage monitor and low fuel level alarms
- 3 configurable maintenance alarms

BENEFITS

- Hours counter provides accurate information for monitoring and maintenance periods
- User-friendly set-up and button layout for ease of use
- Multiple parameters are monitored & displayed simultaneously for full visibility
- The module can be configured to suit a wide range of applications for user flexibility
- PLC editor allows user configurable functions to meet user specific application requirements.
- RS485 Communication port can be used for the Remote Monitoring Communication (Compatible with Cat PLG)

SPECIFICATION

DC SUPPLY

CONTINUOUS VOLTAGE RATING

8 V to 35 V Continuous
5 V for upto 1 minute

CRANKING DROPOUTS

Able to survive 0 V for 100 ms, providing supply was at least 10 V before dropout and supply recovers to 5 V. This is achieved without the need for internal batteries.

LEDs and backlight will not be maintained during cranking.

MAXIMUM OPERATING CURRENT

260 mA at 12 V, 150 mA at 24 V

MAXIMUM STANDBY CURRENT

145 mA at 12 V, 85 mA at 24 V

CHARGE FAIL/EXCITATION RANGE

0 V to 35 V

GENERATOR & MAINS (UTILITY) VOLTAGE RANGE

15 V to 415 V AC (Ph to N)
26 V to 719 V AC (Ph to Ph)

FREQUENCY RANGE

3.5 Hz to 75 Hz

MAGNETIC PICKUP VOLTAGE RANGE

+/- 0.5 V to 70 V

FREQUENCY RANGE

10,000 Hz (max)

INPUTS

DIGITAL INPUTS A TO H

Negative switching

ANALOGUE INPUTS A & D

Configurable as:
Negative switching digital input 0 V to 10 V sensor
4 mA to 20 mA sensor Resistive sensor

ANALOGUE INPUTS B & C

Configurable as:
Negative switching digital input Resistive sensor

OUTPUTS

OUTPUT A & B (FUEL & START)

15 A DC at supply voltage

AUXILIARY OUTPUTS C, D, E, F, G & H

2 A DC at supply voltage

DIMENSIONS OVERALL

216 mm x 158 mm x 43 mm
8.5" x 6.2" x 1.5"

PANEL CUT-OUT

184 mm x 137 mm
7.2" x 5.3"

MAXIMUM PANEL THICKNESS

8 mm
0.3"

STORAGE TEMPERATURE RANGE

-40°C to +85°C
-40 °F to +185 °F

OPERATING TEMPERATURE RANGE

-30°C to +70°C
-22 °F to +158 °F

LEHE2017-01 (11-19)

www.Cat.com/electricpower

©2019 Caterpillar All rights reserved. Materials and specifications are subject to change without notice. The International System of Units (SI) is used in this publication. CAT, CATERPILLAR, their respective logos, "Caterpillar Yellow", the "Power Edge" and Cat "Modern Hex" trade dress as well as corporate and product identity used herein, are trademarks of Caterpillar and may not be used without permission.