



Cat[®] Industrial and Utility Grapples and Forks

SKID STEER LOADERS
MULTI TERRAIN LOADERS

Cat[®] Industrial Grapple Buckets and Forks are designed to easily handle a wide array of bulky, irregularly shaped objects encountered in demolition, industrial, construction, recycling and other aggressive applications.

Industrial grapple buckets are ideal for grasping objects, such as railroad ties, trees, large rocks, brush, industrial and demolition scrap, and recycling debris. Industrial grapple forks are great for piercing and grasping paper, cardboard, wood and light-gauge metal scrap.

Cat Utility Grapple Buckets and Forks are designed to handle light, hard to handle materials encountered on a farm, ranch or landscaping project. The light-duty design offers grasping capabilities for materials, such as loose hay, straw, bedding materials, dry compacted livestock waste, landscaping mulch and pine straw.

FEATURES:

Wide vertical jaw opening

- Wide vertical jaw opening allows for handling of large, bulky material. Industrial grapple buckets are capable of carrying standard industrial drums in the upright position. Industrial grapple forks can easily handle pierceable objects. Utility grapple buckets and forks are ideal for handling bundled material, loose straw and hay, landscaping pine straw and manure.

Note: Utility grapple forks are not designed for piercing and carrying large, round bales.

Hinge pins, cylinder pins and hardware

- Hinge pins, cylinder pins and hardware are plated for corrosion protection and long life. Grease points are conveniently located and protected.

Hardened bucket base edge and fork tines

- Hardened bucket base edge and fork tines provide excellent penetration and wear life. Base edges are predrilled to accept bolt-on cutting edges for protection in high-wear applications.

Cat medium pressure hose, couplings and O-ring face seals

- Caterpillar[®] medium pressure hose, couplings and O-ring face seals provide superior leak free performance and reliability. All hoses are wrapped with nylon woven cordura sleeving for added operator protection. Hydraulic quick disconnects enable fast tool changes.

Quick coupler

- Rugged, opposing edge design holds the work tool securely and allows the operator to quickly change from one high performance Cat Work Tool to another.

Compatibility

Model	Machines
Industrial and Utility Buckets and Forks	216B, 226B, 236B, 232B, 242B, 247B, 252B, 257B, 246C, 256C, 262C, 272C, 277C, 287C, 297C

Cat Industrial and Utility Buckets and Forks

Industrial and Utility Grapple Buckets and Forks



Cat Industrial Grapple Buckets and Forks

- Heavy-duty construction provides superior structural durability in aggressive conditions found in demolition, construction and recycling. Cat Industrial Grapple Buckets incorporate a durable steel bucket, dual full width torque tubes and two vertical reinforcing gussets. Cat Industrial Grapple Forks incorporate a durable steel fork carriage, a full width upper torque tube and a series of internal reinforcing gussets. Both grapple types include two high-strength steel grapple assemblies for superior durability, bending resistance, and clamping force. Independently controlled grapple assemblies allow for grasping of irregularly shaped objects, increasing the versatility of the machine.

Cat Utility Grapple Buckets and Forks

- Lighter duty construction provides an economical means for handling light, hard to handle material encountering in agriculture and landscaping. The grapple assembly can be added to existing utility buckets and forks for added versatility. Cat Utility Grapple Buckets are constructed from utility buckets and use a single, full-width bolt-on grapple assembly with center-mounted cylinder and four gusseted tines. The bolt-on grapple assembly can be easily removed or installed when the need arises. Cat Utility Grapple Forks use the same bolt-on grapple assemblies but are built off the utility fork. The multi-tined utility grapple fork carriage incorporates a predrilled, full-width upper torque tube and three lower gussets to protect against twisting. The lower box channel is predrilled to accept various combinations of pin-on fork tines. A bolt-on rubber bumper limits rack back travel on the larger Cat radial lift machines.

Specifications –Industrial Grapple Buckets

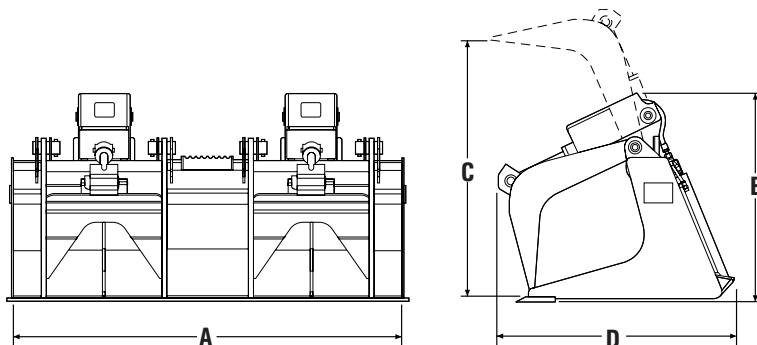

A Width*	mm (in)	1524 (60)	1676 (66)	1829 (72)	1981 (78)
B Height	mm (in)	813 (32)	813 (32)	813 (32)	813 (32)
C Jaw opening	mm (in)	1016 (40)	1016 (40)	1016 (40)	1016 (40)
D Length	mm (in)	940 (37)	940 (37)	940 (37)	940 (37)
Bucket weight**	kg (lb)	435 (959)	448 (988)	462 (1019)	479 (1056)
Sidewall thickness	mm (in)	10 (0.40)	10 (0.40)	10 (0.40)	10 (0.40)
Base edge thickness	mm (in)	19 (0.75)	19 (0.75)	19 (0.75)	19 (0.75)
Cutting edge thickness***	mm (in)	16 (0.63)	16 (0.63)	16 (0.63)	16 (0.63)

* Measured from inside of side plate to inside of side plate; overall width is approximately 50 mm (2 in) wider.

** With base cutting edge only, without ground engaging tools.

*** Optional bolt-on cutting edge.

Specifications – Industrial Grapple Forks

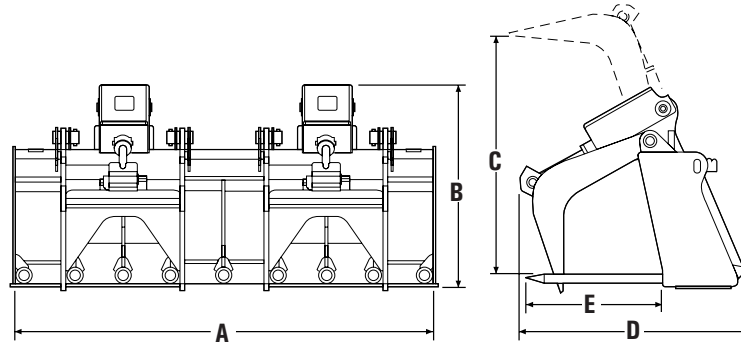

A Width*	mm (in)	1676 (66)	1829 (72)
B Height, grapples closed	mm (in)	813 (32)	813 (32)
C Jaw opening	mm (in)	965 (38)	965 (38)
D Length	mm (in)	940 (37)	940 (37)
E Exposed tine length	mm (in)	559 (22)	559 (22)
Weight	kg (lb)	482 (1063)	530 (1169)
Tine diameter	mm (in)	43 (1.75)	43 (1.75)
Number of tines		9	11

* Measured from inside of side plate to inside of side plate; overall width is approximately 50 mm (2 in) wider.

Specifications – Utility Grapple Buckets

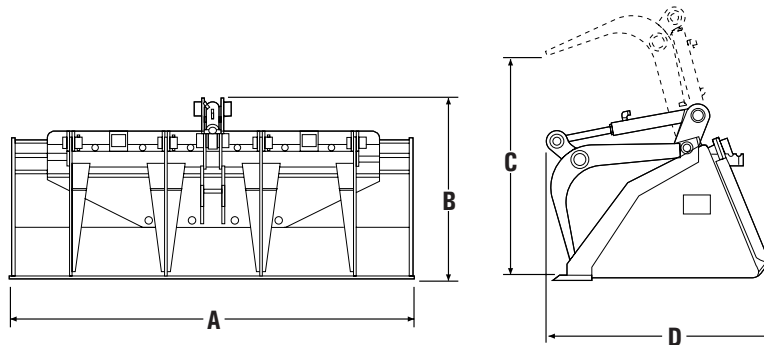

A Width*	mm (in)	1676 (66)	1829 (72)
B Height, grapples closed	mm (in)	739 (29)	739 (29)
C Jaw opening	mm (in)	902 (35.5)	902 (35.5)
D Length	mm (in)	934 (37)	934 (37)
Weight**	kg (lb)	354 (780)	372 (820)
Base edge thickness	mm (in)	19 (0.75)	19 (0.75)
Cutting edge thickness***	mm (in)	16 (0.63)	16 (0.63)

* Measured from inside of side plate to inside of side plate; overall width is approximately 50 mm (2 in) wider.

** Weight with base edge only – no ground engaging tools included.

*** Bolt-on cutting edge.

Cat Industrial and Utility Buckets and Forks

Specifications – Utility Grapple Forks

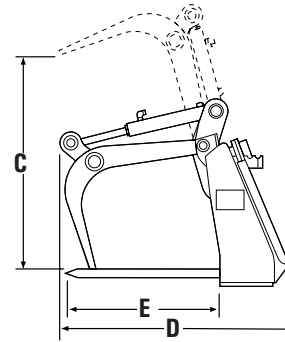
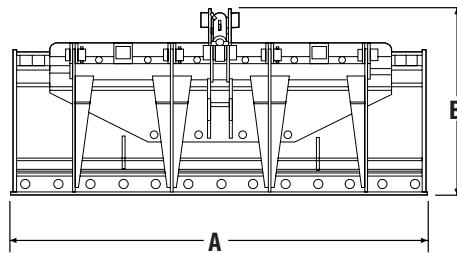

	Utility Grapple Forks				Utility Forks			
A Width*	mm	(in)	1676 (66)	1829 (72)	1676 (66)	1829 (72)	1676 (66)	1829 (72)
B Height, grapples closed	mm	(in)	755 (30)	755 (30)	—	—	—	—
C Jaw opening	mm	(in)	876 (34.5)	876 (34.5)	—	—	—	—
D Length	mm	(in)	940 (37)	940 (37)	940 (37)	940 (37)	940 (37)	940 (37)
E Exposed fork tine length	mm	(in)	627 (24.7)	627 (24.7)	627 (24.7)	627 (24.7)	627 (24.7)	627 (24.7)
Weight	kg	(lb)	290 (640)	322 (710)	195 (430)	227 (500)	195 (430)	227 (500)
Fork tine diameter	mm	(in)	32 (1.25)	32 (1.25)	32 (1.25)	32 (1.25)	32 (1.25)	32 (1.25)
Number of fork tines			7	9	7	9	7	9
Total fork tine holes			13	17	13	17	13	17

* Measured from inside of side plate to inside of side plate; overall width is approximately 50 mm (2 in) wider.

For more complete information on Cat products, dealer services, and industry solutions, visit us on the web at www.cat.com

AEHQ5850 (11-06)

© 2006 Caterpillar
All Rights Reserved
Printed in U.S.A.

Replaces AEHQ5360-02

Materials and specifications are subject to change without notice. Featured machines in photos may include additional equipment. See your Caterpillar dealer for available options.

CAT, CATERPILLAR, their respective logos, "Caterpillar Yellow," and the POWER EDGE trade dress, as well as corporate and product identity used herein, are trademarks of Caterpillar and may not be used without permission.

CATERPILLAR[®]