



Cat[®] Landscape Rakes

SKID STEER LOADERS
MULTI TERRAIN LOADERS

Cat[®] Landscape Rakes are ideal for residential, commercial, agricultural, building construction, lawn care and golf course maintenance applications. They use the scarifying action of the hardened teeth to pulverize, aerate, level and condition the soil, while collecting and depositing rock and debris in the integrated hopper bucket for quick removal. Landscape rakes are designed to operate with the loader traveling in reverse, leaving the soil finely groomed with minimal tire compaction.

FEATURES:

Chain reduction drive system

- The chain reduction drive system features #80H roller chain for strength and durability, a variable speed, uni-directional gerotor motor for maximum performance and versatility and a cartridge relief valve for system protection when an object becomes lodged in the raking system.

High-strength carbon steel teeth

- High-strength carbon steel teeth are hardened for maximum strength, durability and wear life in the toughest soil conditions. Teeth are easily weld replaceable or rebuildable to extend rake life.

Quick dumping capability

- Quick dumping capability is accomplished with a poppet check valve that stops flow to the hydraulic motor and

directs flow to the rake head cylinder. Once the hopper bucket is full, simply reverse flow to actuate the rake head cylinder and dump the bucket.

Durable conveyor chain

- A durable #2060H conveyor chain provides strength, durability and long life in a variety of soil conditions.

Bolt-on conveyor tubes

- Bolt-on conveyor tubes allow for easy replacement and serviceability.

Cat XT[™]-3 ES hose, couplings and O-ring face seals

- Cat XT-3 ES hose, couplings and O-ring face seals provide superior, leak-free performance and reliability. All hoses are wrapped with nylon woven cordura sleeving for added operator protection. Hydraulic quick disconnects enable fast tool changes.

Quick coupler

- Rugged, opposing edge design holds the work tool securely and allows the operator to quickly change from one high performance Cat Work Tool to another.

Compatibility

Model	Machines
LR15B	216B, 226B, 232B, 236B, 242B, 247B, 252B, 257B, 246C, 256C, 262C, 272C, 277C, 287C, 297C
LR18B	236B, 247B, 252B, 257B, 246C, 256C, 262C, 272C, 277C, 287C, 297C

Cat Landscape Rakes

Specifications

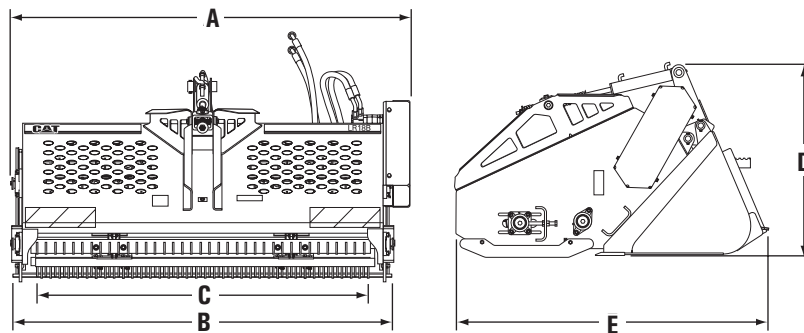

			LR15B		LR18B	
A Overall width	mm (in)		1683	(66)	1990	(78)
B Working width	mm (in)		1576	(62)	1883	(74)
C Raking width	mm (in)		1384	(55)	1655	(65)
D Overall height	mm (in)		989	(39)	989	(39)
E Overall length	mm (in)		1620	(64)	1620	(64)
Unit weight	kg (lb)		595	(1,312)	653	(1,440)
Bucket capacity (struck)*	m ³ (yd ³)		0.31	(0.4)	0.34	(0.44)
Bucket capacity (struck)*	m ³ (ft ³)		0.31	(10.8)	0.34	(11.9)
Drive chain			#80H		#80H	
Conveyor chain			#2060H		#2060H	
Required hydraulic flow	L/min (gpm)		42-83	(11-22)	42-83	(11-22)
Optimal hydraulic pressure	bar (psi)		145-227	(2,100-3,300)	145-227	(2,100-3,300)
Effective displacement	cm ³ (in ³)		484.5	(29.5)	484.5	(29.5)
Driven shaft speed			165 rpm @ 80 l/min		165 rpm @ 80 l/min	
Torque			1774 N•m (1,310 lb•ft) @ 230 bar (3,336 psi)		1774 N•m (1,310 lb•ft) @ 230 bar (3,336 psi)	
Number of hard-faced tines			372		444	
Rock size range	mm (in)		19-52	(0.75-6)	19-52	(0.75-6)

* Rated struck capacities shown as per ISO7546: 1983 and SAE J742 FEB85.
Theoretical values calculated at 100% efficiency.

For more complete information on Cat products, dealer services, and industry solutions, visit us on the web at www.cat.com

AEHQ5830 (11-06)

© 2006 Caterpillar
All Rights Reserved
Printed in U.S.A.

Replaces AEHQ5699

Materials and specifications are subject to change without notice. Featured machines in photos may include additional equipment. See your Caterpillar dealer for available options.

CAT, CATERPILLAR, their respective logos, "Caterpillar Yellow," and the POWER EDGE trade dress, as well as corporate and product identity used herein, are trademarks of Caterpillar and may not be used without permission.

CATERPILLAR®