



Cat[®] Augers

SKID STEER LOADERS
MULTI TERRAIN LOADERS

Cat[®] Augers are used for drilling holes for footings, fencing, signs, trees and shrubs in construction, agricultural and landscaping applications. They are designed with the right amount of speed and torque for maximum productivity in a broad range of soil types.

FEATURES:

Three different drive systems

- The direct drive A14B features a variable speed, bi-directional, gerotor style hydraulic motor that generates optimal bit speed and output torque for light- to moderate-duty work.
- The single reduction planetary drive A19B features a variable speed, bi-directional, gerotor style hydraulic motor mounted to a planetary gear box for optimal bit speed and output torque for moderate- to heavy-duty applications. The additional output torque provides better performance with larger diameter bits.
- The double reduction planetary drive A26B features a variable speed, bi-directional, hydraulic gear motor mounted to a planetary gear box for optimal bit speed and output torque for moderate to heavy-duty, high-performance drilling requirements. Its exceptional, high-torque output capabilities provide excellent performance in the toughest conditions with the largest diameter bits.

Exclusive Cat mounting bracket

- An exclusive Cat mounting bracket is common to all models. It incorporates full-width upper and lower torque tubes, an articulated joint, cradle, feet stand, step and bracket commonality. These features provide superior structural reinforcement, positioning flexibility, easy transportation, near-vertical storage, easy work tool engagement and mounting versatility.

Cat XT™ and medium pressure hose, couplings and O-ring face seals

- Cat XT and medium pressure hose, couplings and O-ring face seals provide superior, leak-free performance and reliability. All hoses are wrapped with nylon woven cordura sleeving for added operator protection. Hydraulic quick disconnects enable fast tool changes.

Auger bits

- Bits are rugged and adaptable to a number of projects.

Quick coupler

- Rugged, opposing edge design holds the work tool securely and allows the operator to quickly change from one high performance Cat Work Tool to another.

Compatibility

Model Machines

A14B 216B, 226B, 232B, 236B, 242B, 247B, 252B, 257B, 246C, 256C, 262C, 272C, 277C, 287C, 297C

A19B 216B, 226B, 232B, 236B, 242B, 247B, 252B, 257B, 246C, 256C, 262C, 272C, 277C, 287C, 297C

A26B* 246C, 256C, 262C, 272C, 277C, 287C, 297C

* Requires high flow or high flow XPS option on machine.

Model Bit Diameters mm (in)

A14B 152 (6), 229 (9), 305 (12), 457 (18), 610 (24), 762 (30), (tree) 610 (24)/305 (12)

A19B 152 (6), 229 (9), 305 (12), 457 (18), 610 (24), 762 (30), 914 (36), (tree) 610 (24)/305 (12), 914 (36)/457 (18)

A26B 152 (6), 229 (9), 305 (12), 457 (18), 610 (24), 762 (30), 914 (36), (tree) 610 (24)/305 (12), 914 (36)/457 (18)

Cat Augers

Specifications

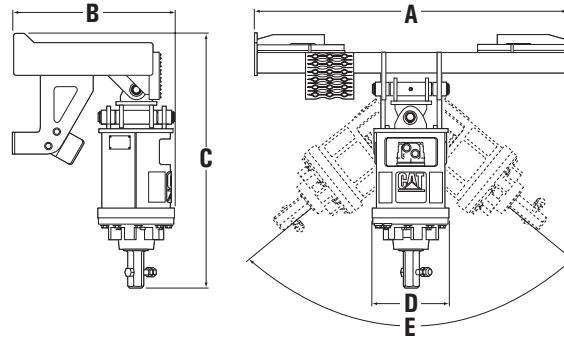

			A14B		A19B		A26B	
A Overall width w/bracket	mm (in)		1152	(45)	1152	(45)	1152	(45)
B Overall length w/bracket	mm (in)		598	(24)	598	(24)	598	(24)
C Overall drive unit height	mm (in)		1020	(40)	934	(37)	978	(39)
D Housing diameter	mm (in)		252	(10)	252	(10)	252	(10)
E Swing range			102°		102°		102°	
Drive unit weight w/ hydraulic lines w/o bit	kg (lb)		101	(223)	75	(165)	91	(201)
Mounting frame weight w/clevis	kg (lb)		91	(201)	91	(201)	91	(201)
Total weight w/o bit	kg (lb)		192	(423)	166	(366)	182	(401)
Required hydraulic flow range	L/min (gpm)		42-80	(11.1-21.1)	42-80	(11.1-21.1)	95-130	(25.1-34.3)
Optimal hydraulic pressure range	bar (psi)		145-230	(2103-3336)	145-230	(2103-3336)	207-290	(3002-4206)
Effective displacement	cc/rev (in ³)		629.1	(38.39)	250.0	(15.26)	43.77	(2.67)
Drive shaft torque @ max pressure*	N•m (lb•ft)		2304	(1700)	4118	(3037)	6826	(5034)
Bit speed (drive shaft) @ max flow	rpm		127		71		81	
HEX output shaft size	mm (in)		51	(2)	51	(2)	51	(2)

* Theoretical values calculated at 100% efficiency.

Auger Bits and G.E.T. Options

Bit type		Std.	Std.	Std.	Std.	Std.	Std.	Std.	Tree	Tree
Bit diameter	mm (in)	152 (6)	229 (9)	305 (12)	457 (18)	610 (24)	762 (30)	914 (36)	610 (24)	914 (36)
									305 (12)	457 (18)
Bit weight	kg (lb)	23 (51)	34 (75)	46 (101)	65 (143)	92 (203)	128 (282)	173 (381)	74 (163)	140 (309)
Bit ext.	mm (in)	305 (12)	305 (12)	305 (12)	305 (12)	305 (12)	305 (12)	305 (12)	305 (12)	305 (12)
		610 (24)	610 (24)	610 (24)	610 (24)	610 (24)	610 (24)	610 (24)	610 (24)	610 (24)
Teeth		2	4	4	6	8	10	12	9	13

For more complete information on Cat products, dealer services, and industry solutions, visit us on the web at www.cat.com

AEHQ5829 (11-06)

© 2006 Caterpillar
All Rights Reserved
Printed in U.S.A.

Replaces AEHQ5468-01

Materials and specifications are subject to change without notice. Featured machines in photos may include additional equipment. See your Caterpillar dealer for available options.

CAT, CATERPILLAR, their respective logos, "Caterpillar Yellow," and the POWER EDGE trade dress, as well as corporate and product identity used herein, are trademarks of Caterpillar and may not be used without permission.

CATERPILLAR®